



SEACHOICE

Aerator/Pump System Manual

KIT INCLUDES

350 GPH pump / Tube clips / Suction cup base

Battery clips / Aerator tube / Hosepipe

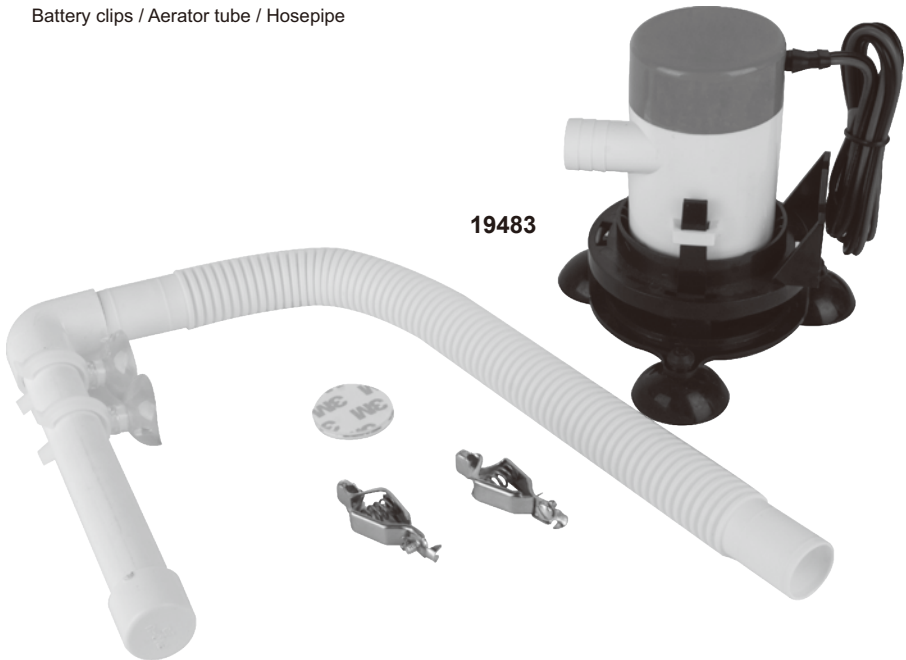

FEATURES

Aerates any portable livewell / baitwell bucket or cooler.

A fully adjustable spray head to set the rate of water flow.

Move more water and oxygen into livewell tanks to keep fish active.

Cooler-running motors, premium materials, watertight seals and waterproof wiring.

WARNING

This pump is designed for use with fresh and salt water. Use with any other medium, including particularly hazardous, caustic or corrosive substance, could result in damage to the pump, the surrounding environment and injury to persons or property, including possible exposure to hazardous substances.

INSTALLATION

1. Clean surface of sand, grease, etc and press pump suction cups firmly in place.
2. Spray tube may be removed and shortened if necessary.
3. If battery is close enough, clip wires to the battery with the battery clips provided. If additional lengths of wire are needed, use 18 gauge wire. On installation over 20 feet, use 14 gauge wire. Make sure all wire connections are completely waterproof, and out the water.
4. The black lead is negative (-). Attach the black lead to the negative (-) side of the battery. The brown lead to the positive (+) side of the battery. Install a 2.0 amp fuse in the positive (+) lead as close to the battery as possible.

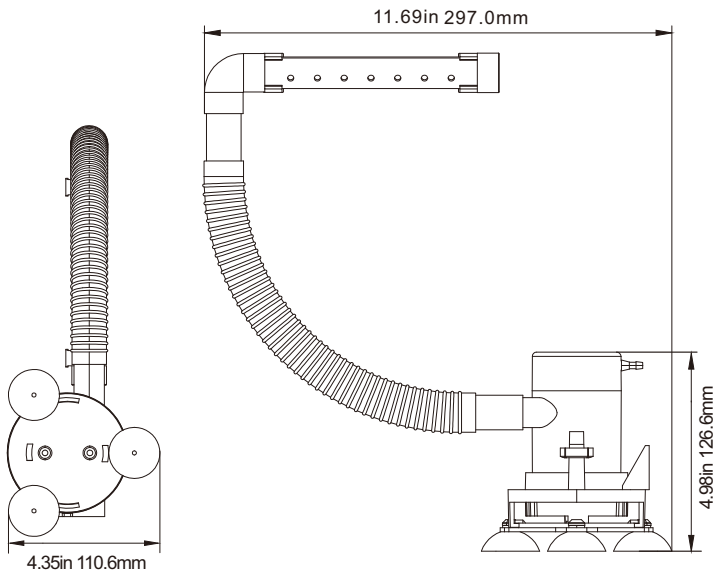

Dimension